

Index Plungers - Pull Grip

flange mounting - extended pin



32530

for cap screw
DIN 912 / ISO 4762-M5

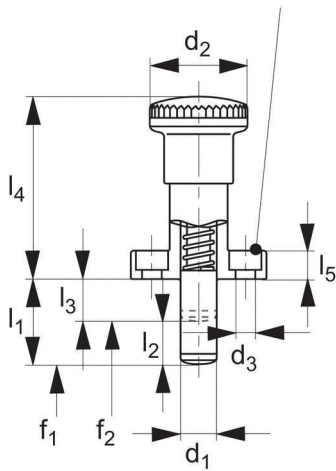

non locking

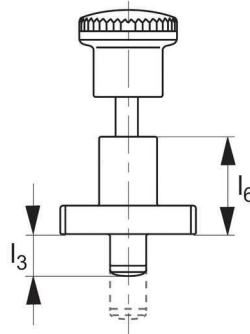

locking

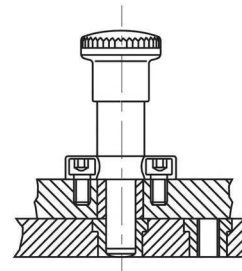
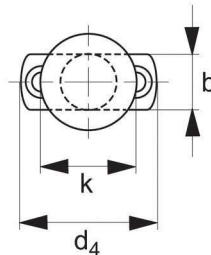
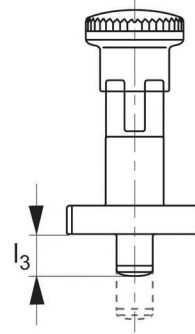

mounting example



Material

Body: steel blackened.
Pin: hardened and ground.
Grip: thermoplastic PA6, black.

Technical Notes

"Locking" type- enable pin to be held in retracted position; pull back grip, turn 90° to engage 'locking' on a notched catch.

"Non Locking" type- pin simply springs back when grip is released. **Due to extended length pin does not fully retreat into plunger body when grip activated - note dimension l_3 for length pin remains exposed.**

Extended pin assists locating and indexing of components. Due to its extended length the pin does not fully retract flush to the plunger body - please note dimensions l_1 for extended pin length and l_3 for retracted pin length. Pin is tolerated to h7 for improved location accuracy. Accuracy dependant upon suitable tolerance of bush, we suggest H7, with min. pin engagement to dim. l_3 .

Tips

Grip non-removable.
Spring Loads* = statistical average.

Order No.	Type	d_1 h7	l_1	l_2 Strok e	l_3	b	d_2	d_3	d_4	k	l_4	l_5	l_6	Sprin		$\Delta \pm$ g
														g load*	g load*	
														f_1 N	f_2 N	
32530.W0081	Non Locking	8	20	10	10	16	28	5,5	38	26	51	8	27	8,5	28	74
32530.W0083	Non Locking	8	26	10	16	16	28	5,5	38	26	51	8	27	8,5	28	77
32530.W0084	Non Locking	8	30	10	20	16	28	5,5	38	26	51	8	27	8,5	28	78
32530.W0102	Non Locking	10	24	12	12	16	28	5,5	38	26	51	8	27	9,5	38	77
32530.W0104	Non Locking	10	32	12	20	16	28	5,5	38	26	51	8	27	9,5	38	80
32530.W0281	Locking	8	20	10	10	16	28	5,5	38	26	51	8	27	8,5	28	80
32530.W0282	Locking	8	22	10	12	16	28	5,5	38	26	51	8	27	8,5	28	80
32530.W0283	Locking	8	26	10	16	16	28	5,5	38	26	51	8	27	8,5	28	83
32530.W0284	Locking	8	30	10	20	16	28	5,5	38	26	51	8	27	8,5	28	84
32530.W0202	Locking	10	24	12	12	16	28	5,5	38	26	51	8	27	9,5	38	83
32530.W0204	Locking	10	32	12	20	16	28	5,5	38	26	51	8	27	9,5	38	100



A wide selection of solutions

- Locating and positioning.
- Indexing.
- Securing.
- Positive locking.
- Rapid adjustment of all kinds of tables, platforms and fixtures.
- Machine and fixture design.
- OEM products.
- Sports equipment.
- Medical aides (wheelchairs etc.).
- Aerospace.
- Machine cabinets.

Applications



Steel with plastic grip



Stainless with plastic grip

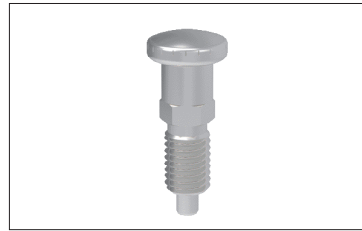

Stainless body and grip

Materials



Locking (park)



Non locking (spring back)

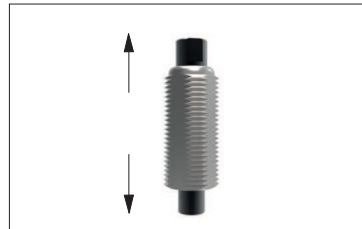

Push pull

Locking or non locking



Standard grip



Lever grip



T-handle



Pull ring



Threaded for bespoke handle

Handling and actuation methods



Fine threaded (standard)



Coarse thread



Flange mount

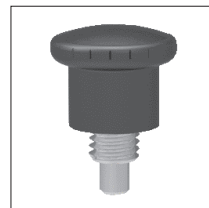

Thin wall mount



Weldable

Mounting options

- Unless otherwise stated, grips on index plungers are not removeable.
- Many of the pins on index plungers are toleranced to either the pin or the hole. Please refer to the specific product table.
- Index plungers are not recommended for shear load applications.

Pin Tol. Hole Tol.

①	h_9	+0,03 +0,08
②	-0,02 -0,04	H ₇

Additional technical notes

- s** Stroke, or movement of plunger's pin.
- f₁** The force required in Newtons (N) to over come the static strength of the spring and achieve initial movement of the plunger's pin.
- f₂** The force required in Newtons (N) to fully compress the spring until the pin is fully depressed against the plunger's body.

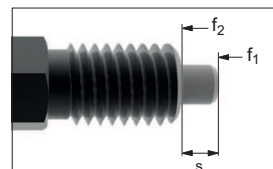

Spring loads

Computing the strength of index plungers

for shear loads / flexure loads of the plunger pin



Flexure loads

As soon as a gap l exists between the mounting plate in which the index plunger is installed, and the mating or base plate, the load must be considered to be as per a flexure load, with rod clamped at one side.

With this approach, the calculation is made against the bending of the index plunger.

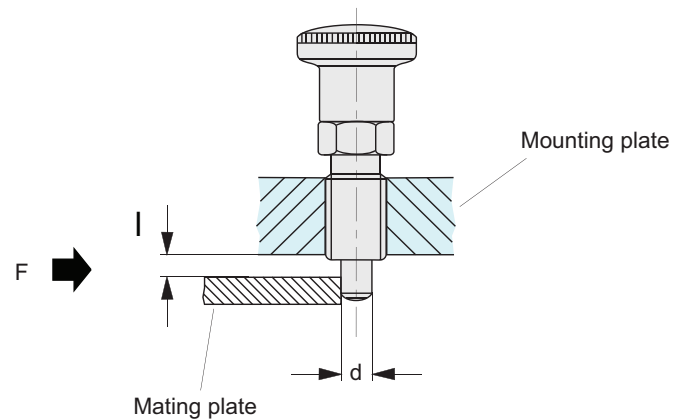

Formulas for computation

Resistance torque

$$W = \frac{\pi \times d^3}{32}$$

Flexural stress

$$M_b = \sigma_b \times W$$

Flexural strength

$$F = \frac{M_b}{l} = \frac{\sigma_b \times \pi \times d^3}{l \times 32}$$

Material characteristics

The yield or substitute yield limit ($R_e / R_p 0,2$) shown in the table opposite has been determined in tension tests involving tension specimen in accordance with DIN 50125-B6-30.

These tests constitute the basis for the load bearing details given.

Material Description	Material no.	R_e in N/mm ² (≈ per. flexural tension σ_b)
C45Pb	1.0504	560
X 10 CrNiS 18 9A	ISI 303	580

Calculation example, load values

Example:

Index plungers with a bolt diameter of 5 mm made of steel with a yield limit of $R_e = 560 \text{ N/mm}^2$, calculation against permanent deformation, the maximum permissible flexural strength is calculated as:

$$F_{\text{per}} = \frac{560 \text{ N/mm}^2 \times \pi \times (5\text{mm})^3}{2\text{mm} \times 32} = 3430 \text{ N}$$

d Bolt diameter	max. flexural strength F in N, acc. to material and gap l differentiated			
	C45Pb/1.0504		X 10 CrNiS 18 9/1.4305	
	$l = 2 \text{ mm}$	$l = 3 \text{ mm}$	$l = 2 \text{ mm}$	$l = 3 \text{ mm}$
3	740	490	760	510
4	1750	1170	1820	1210
5	3430	2290	3550	2370
6.5	930	3950	6140	4100
8	14070	9380	14570	9710
10	27480	18320	28470	18980
12	47490	31660	49190	32790
16	90070	102940	93290	119020

Safety information

On principle, the design also needs an adequate safety coefficient to be taken into account. The usual safety coefficients under static load 1.2 to 1.5; pulsating 1.8 to 2.4 and alternating 3 to 4.

Disclaimer:

You should carry out your own test series to verify whether a certain product is suitable for your specific applications.

Computing the strength of index plungers

for shear loads / flexure loads of the plunger pin



Shear loads

Providing only a very small gap exists between the mounting plate in which the index plunger is installed, and the mounting plate or base plate, the load can be calculated as a clean shear action.

As this is normally not the case, the "flexure" load should be used - see following page.

Approximately 80 % of the bolt's tensile strength is assumed for the shear strength. This approach calculates against the tensile strength R_m , i.e. against the index pin shearing off.

To ensure the permanent and proper function of the index plunger, the yield limit R_e must be considered in place of the tensile strength R_m .

Stop using the index plunger if the pin is damaged or deformed.

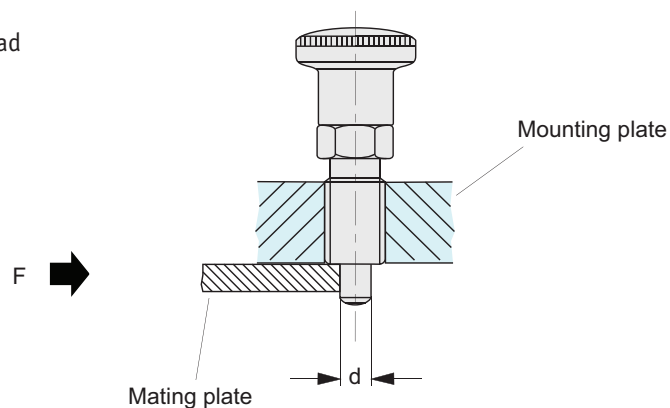

Formulas for computation

Bolt cross-section

$$S = \frac{d^2 \times \pi}{4}$$

Limit tension

$$\tau_a = 0,8 \times R_m$$

Shear force

$$F = S \times \tau_a = \frac{d^2 \times \pi}{4} \times 0,8 \times R_m$$

Material characteristics

The tensile strength shown in the table opposite (R_m) and the yield or substitute yield limit ($R_e / R_p 0,2$) have been determine in tension tests involving tension specimen in accordance with DIN 50125- B6-30

These tests constitute the basis for the load bearing details given.

Material Description	Material no.	R_e in N/mm ²	R_m in N/mm ²
C45Pb	1.0504	560	640
X 10 CrNiS 18 9A	ISI 303	580	740

Calculation example, load values

Example:

Index plungers with a bolt diameter of 6 mm made of Stainless Steel with a yield limit of $R_e = 580 \text{ N/mm}^2$, calculation against permanent deformation, the maximum permissible shear stress is calculated as:

$$F_{per} = \frac{(6 \text{ mm})^2 \times \pi}{4} \times 0,8 \times 580 \text{ N/mm}^2 = 13120 \text{ N}$$

d Bolt diameter	max. force F in N, acc. to material and strength value differs			
	C45Pb/1.05045		X 10 CrNiS 18 9/1.4305	
	at R_e	at R_m	at R_e	at R_m
3	3160	3610	3270	4180
4	5620	6430	5830	7430
5	790	10050	9110	11620
6	12660	14470	13120	16730
8	22510	25730	23320	29750
10	35180	40210	36440	46490
12	50660	57900	52470	66950
16	90070	102940	93290	119020

Safety information

On principle, the design also needs an adequate safety coefficient to be taken into account. The usual safety coefficients under static load 1.2 to 1,5; pulsating 1.8 to 2.4 and alternating 3 to 4.

Disclaimer:

You should carry out your own test series to verify whether a certain product is suitable for your specific applications.